

DESCRIPTION

The ESB12 & 24 units include a circuit-breaker/isolator and optional terminal box. 12V or 24V configuration must be decided by ordering the correct variant and cannot be changed by the user. This equipment is designed specifically for use in hazardous areas (ATEX directive 2014/34/EU) and is corrosion resistant with a 316 stainless casing. ESB12 & 24 units contain deep cycle batteries protected with a 50A MCB isolator and are not suited to engine cranking applications.



ESB24T

TECHNICAL DATA

Type of Protection	Increased-Safety/Explosion-Proof			
ATEX/IEC/CENELEC Marking	Ⓜ II 2 G, Ex db eb IIB T4 Sira 06ATEX3314X & IECEx SIR 06.0088X			
Ambient Temperature	-20°C to +48°C			
Type	ESB12	ESB12T	ESB24	ESB24T
Output (12 Cells)	12V/110AH	12V/110AH	24V/55AH	24V/55AH
Weight	58 Kg	62 kg	58 kg	62 kg
Part Number	300811093/12	300825083/12	300811093/24	300825083/24
Terminal box fitted	No	Yes	No	Yes

IP Rating

Ex d Isolator, Ex e Terminal Box, Battery Cells	IP66
Battery Terminals Inside Exe Enclosure	IP23

**The flameproof isolator and battery box include the warning:
DO NOT OPEN WHEN AN EXPLOSIVE ATMOSPHERE MAY BE PRESENT.**

INSTALLATION

This equipment must be installed and maintained in accordance with IEC/EN 60079-14 and 17. Failure to observe any instructions in this data sheet may invalidate any warranty agreement.

Locate the equipment where it is protected from the weather and direct water jets. Fix the battery to the skid or frame using four M10 screws via the holes provided at the base of the case.

The enclosure should be earthed to the frame via the stainless M8 stud assembly at the base of the outer case. Check for continuity after mounting.

INSTALLATION (Continued)

Isolate the battery supply (using switch) prior to working inside the Ex d isolator or Ex e terminal box.

Cable glands must be ATEX/IECEx certified. The ESB12 and ESB24 units should be fitted with an M25x1.5 Ex d gland. The ESB12T and ESB24T units should be fitted with an M25 Ex e gland and retaining nut.

After mounting, it is essential that the external supply cables are fixed locally to prevent them being pulled or twisted using a suitable clamp. ESB12T and ESB24T units are provided with an optional bracket to facilitate this. All external cables should be protected from mechanical damage by the use of a guard or conduit. Alternatively, armoured cable may be used.

1) Units with Terminal Boxes (ESB12T/ESB24T):

Terminal boxes are pre-fitted with Weidmuller terminals (only Weidmuller WDU/WPE terminals are included in this product certification).

The following tightening torques and maximum current values apply:

Ident	Terminal	Terminal Tightening Torque (Nm)	Maximum current (Amps)
10 to 17 + E	WDU/WPE 6	0.8 to 1.6	36
1 to 9	WDU/WPE 16	3.0 to 4.0	66

The battery certification allows these terminals to be replaced by Weidmuller WDU/WPE terminals in alternative sizes – for further information, consult the table below or see www.weidmuller.co.uk

Electrical Data for Weidmuller Terminals

TYPE	Rated current (A)	Resistance across terminals	Cross section (mm ²)	Conductor range single wire (mm ²)
WDU 2.5	21	369 $\mu\Omega$	2.5	0,5-4,0
WDU 4	28	298 $\mu\Omega$	4	0,5-6,0
WDU 6	36	176 $\mu\Omega$	6	0,5-10,0
WDU 10	50	152 $\mu\Omega$	10	1,5-16,0
WDU 16	66	161 $\mu\Omega$	16	1,5-25,0
WDU 35	109	145 $\mu\Omega$	35	2,5-35,0
WPE 2.5	N/A	833 $\mu\Omega$	2,5	0,5-4,0
WPE 4	N/A	643 $\mu\Omega$	4	0,5-6,0
WPE 6	N/A	256 $\mu\Omega$	6	0,5-10,0
WPE 10	N/A	221 $\mu\Omega$	10	1,5-16,0
WPE 16	N/A	178 $\mu\Omega$	16	1,5-25,0
WPE 35	N/A	173 $\mu\Omega$	35	2,5-35,0

INSTALLATION (Continued)

Excess currents must be avoided to prevent the conductors, terminals and cable glands exceeding their operating temperatures.

To avoid overheating, the maximum power dissipation within the terminal box must be calculated to EN/IEC 60079-7 Annex E, E.2. A limit of 8W may be dissipated if 85°C cables are installed or 17W if 100°C cables are installed. For systems supplied by Pyroban, this calculation is already made.

To avoid calculating the 8W power dissipation, the illustrated pre-assessed configuration may be made:

In this example combined with the table below, one or two alternators may be wired, but only one alternator may run at a time to avoid overheating*.

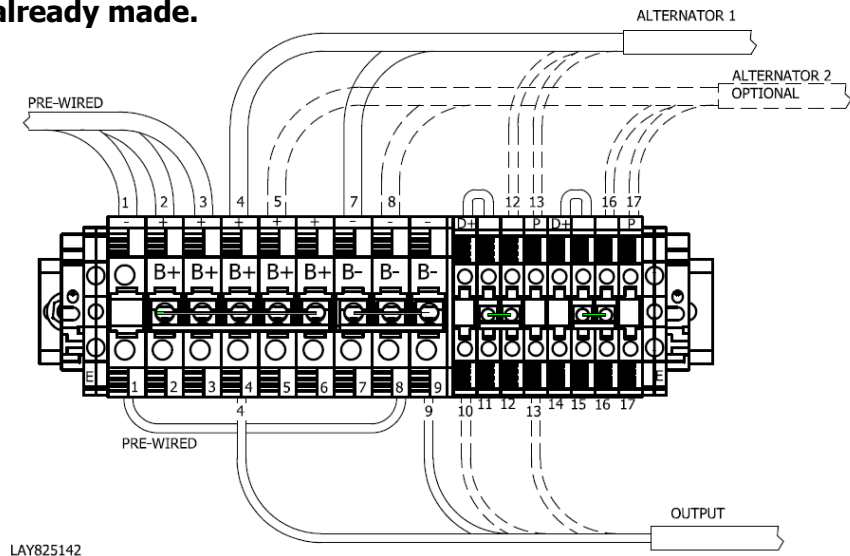

*Other systems with 2 alternators running at the same time are acceptable if the heat dissipation calculation shows that a reduced current or duty cycle leads to a terminal box power dissipation of under 8W.

In this configuration, the following cable and current parameters should also be followed:

Top Terminal Connections				
Ident	Function	Min Cable section	Max Current	Max cable length inside enclosure
4	Alternator 1 +Ve	5.2mm ² (10AWG)	45A	27cm
5	Alternator 2 +Ve (optional)	5.2mm ² (10AWG)	45A	27cm
7	Alternator 1 -Ve	5.2mm ² (10AWG)	45A	27cm
8	Alternator 2 -Ve (optional)	5.2mm ² (10AWG)	45A	27cm
12	Alternator 1 pre-excitation (optional)	0.75mm ²	5A	27cm
13	Alternator 1 charge indicator (optional)	0.75mm ²	5A	27cm
16	Alternator 2 pre-excitation (optional)	0.75mm ²	5A	27cm
17	Alternator 2 charge indicator (optional)	0.75mm ²	5A	27cm
Bottom Terminal Connections				
Ident	Function	Min Cable section	Max Current	Max cable length inside enclosure
4	+Ve main supply out	6mm ²	45A	27cm
9	-Ve main supply out	6mm ²	45A	27cm
10	Alternator Pre-excitation (optional)	0.75mm ²	5A	27cm
13	Charge indicator (optional)	0.75mm ²	5A	27cm

INSTALLATION (Continued)

External Cable Clamping:

For units with terminal boxes, to prevent twisting of cables, a bracket is provided which cables may be tied to.

Fix the bracket to the side of the battery box using M6 screws.

Cable Tie

Bracket

M6 Screw

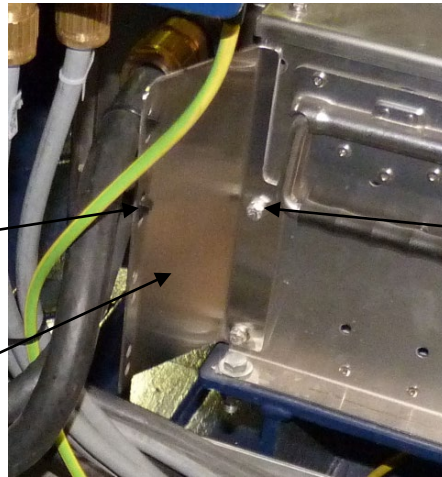

2) Units without Terminal Boxes (ESB12/ESB24)

Connections should be made using the Ex d isolator box via the M25 gland. Remove the lid and connect as shown. The MCB must be connected via the battery and the output lead.

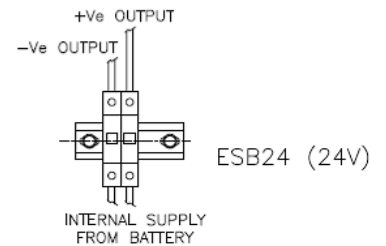
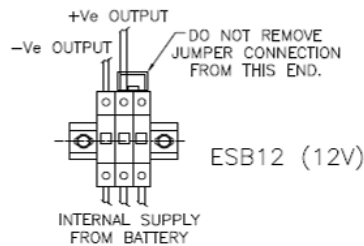

DIMENSIONS

ESB12T/ESB24T

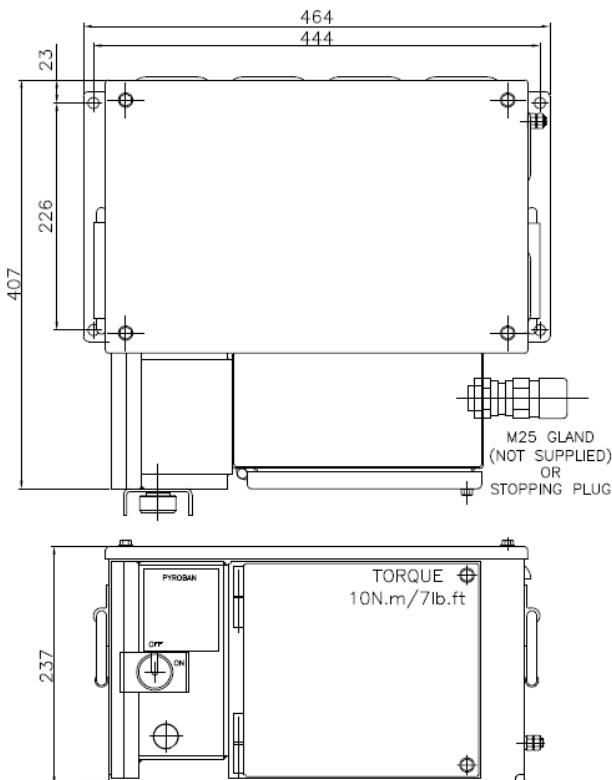

BATTERY TIGHTENING TORQUES
APPLY TO BOTH BATTERY TYPES

ESB12/ESB24

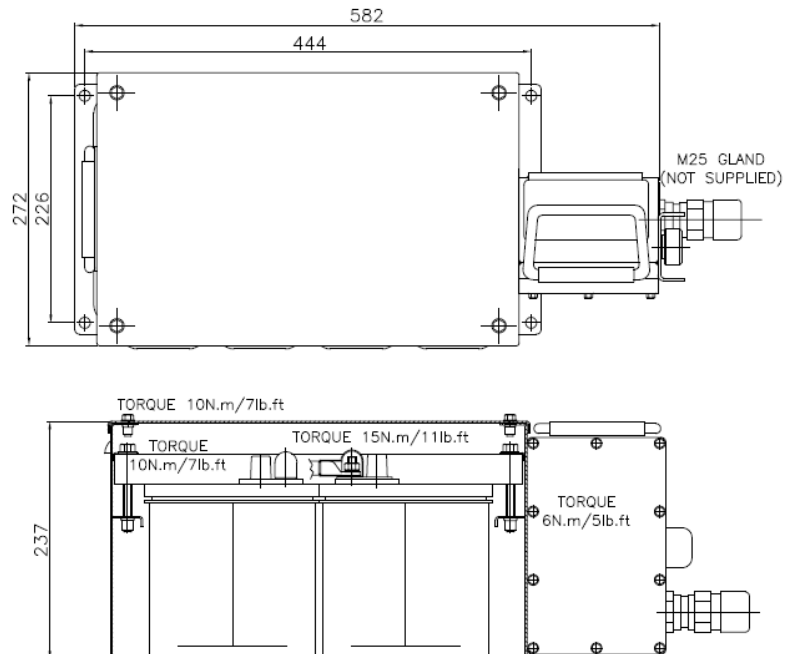

BATTERY CHARGING

Charging of the Pyroban ESB battery in hazardous areas must take into consideration over-charging faults. The charging circuit must be such that under any single fault, the following parameters are not exceeded:

		12V units	24V units
Alternator Charging:	Output must not exceed:	15V	30V
Charging with Battery charger:	Max output 10A*	15V	30V

Any charging system that is installed within the potential explosive atmosphere must be certified as compliant with EN/IEC 60079:0 and any appropriate sub-standard (Pyroban FPA alternators include a double regulator to achieve compliance).

If relevant, the charging circuit shall be separated from any other voltage source(s). The separation shall satisfy table 2 of EN/IEC 60079-7:2015.

**Rapid recharging is acceptable if the battery does not exceed 50°C. The charge voltage must be limited to 15.6V for a 12V battery and 31.2V for a 24V battery.*

BATTERY SAFETY

Acid Hazard

The batteries are AGM (Absorbed Glass Mat) type and acid will not normally leak, even from a cracked case. In the event of contact of acid with the skin, immediately drench in clean water and remove any contaminated clothing. Wash eyes under running water for a minimum of 10 minutes and seek medical attention.

Electrical Energy

Burns may occur from the heating of tools and conductive objects in contact with live conductors. Rapid discharging can cause gaseous fumes leading to explosions.

Isolate the battery where possible prior to working on electric circuits. Exercise caution when working with metallic tools or conductors to prevent short circuits and arcing.

For burns cool the area with water, apply a sterile dressing and seek medical attention if necessary.

Emission of Gasses

Hydrogen and oxygen are emitted during charging and can cause an explosive concentration. Install in a ventilated area. Avoid exposing batteries to ignition sources such as sparks and hot surfaces.

Weight

Both battery assemblies are heavy and awkward to handle. Do not lift alone or use a suitable lifting device to avoid personal injury. Conduct a risk assessment if necessary.

Handling

Always wear proper eye, face and hand protection when working with battery. Never lean over battery while boosting, testing, or charging.

Disposal

Batteries contain acid and lead compounds, should not be burnt and must be disposed of in accordance with the local environmental regulations.

Batteries may alternatively be returned to Pyroban for appropriate disposal.

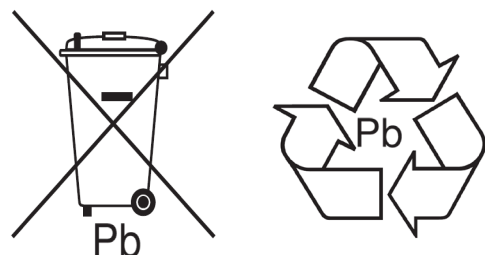

MAINTENANCE

This should be carried out in a safe area.

Every 12 months or 1500 hours operation whichever sooner:

- Check that the supply cables are in good condition and fixed in their original position.
- Check that the cable glands are tight.
- Check that the mounting fixings are tight.
- Check that the isolator operates freely and isolates the battery output.
- Inspect the unit for mechanical damage, contact Pyroban Customer services for advice on repair or replacement.

The internal battery is not serviceable; do not attempt to fill with water or acid.

Should any repairs be made to the flameproof isolator enclosure, please note that the maximum constructional gap (i_c) is less than that required by Table 1 of EN/IEC 60079-1 on the following joints:

Flanged lid to enclosure 0.05mm: Actuator cylindrical joint to enclosure 0.15mm

Isolator enclosure flameproof joints are not intended to be repaired.

STORAGE

Store fully charged, upright in a cool (Ideally 10°C to 20°C), dry and ventilated place. Storage at low charge causes the plates to sulphate and permanently deteriorates the performance. Check every few months to make sure the open circuit terminal voltage has not dropped below 12.4 Volts (24.8 Volts). Recharge if necessary.

BATTERY REPLACEMENT

Genuine Pyroban parts should be ordered to ensure certification is not invalidated.

The internal battery units may only be replaced **AS A PAIR** by the following specially tested part: Optima BT-DC4.2 Pyroban part number 300994516/S

To replace the batteries, first isolate the supply. Remove the battery lid and retaining bar. Take care not to short the battery terminals when removing connections. Replace wiring in the original layout. Replace any nuts and shake-proof washers and tighten fixings to the values on page 4.

Only the hydraulically crimped terminals are to be used for connection to the battery terminal posts. The taper post terminals are not approved and not to be used.

Re-fit insulators provided so that no conductive parts are exposed. The minimum allowable clearance between the terminal or bare supply cable to the battery casing is 35mm.

Replace the lid and tighten fixings to the values on page 4.

DECLARATION OF CONFORMITY

We, Pyroban Limited, Dolphin Road, Shoreham-by Sea, Sussex, BN43 6QG, UK, declare that the component mentioned in this data sheet has been designed and manufactured in accordance with the essential health and safety requirements of Directive 2014/34/EU (ATEX) inclusive of subsequent amendments. Compliance with these Directives is established by meeting the technical requirements of the relevant CEN and CENELEC standards.

Dave Waring



OTHER INFORMATION

Nothing contained in this brochure is intended to extend any warranty or representation, expressed or implied, regarding the products described herein. Any such warranties or other terms and conditions of sale of products shall be in accordance with Pyroban's standard terms and conditions of sale for such products, which are available upon request. Specifications and machinery may be altered without notice at any time.

CONTACT

Pyroban Limited Dolphin Road Shoreham-by-Sea W. Sussex BN43 6QG United Kingdom

Telephone: +44 (0) 1273 456800

Email: info@pyroban.com

www.pyroban.com