

Image shown may not reflect actual engine configuration

PACKAGE SPECIFICATIONS

I-6, 4-Stroke-Cycle Diesel

Emissions	CCNR Stage 2/ U.S.A. 40 CFR Part 94 Marine Tier 2
Peak Torque at Speed	296 N•m (218 lb-ft) @ 1000 rpm
Bore	105 mm (4.13 in)
Stroke	127 mm (5 in)
Displacement	4.4 L (268.5 in ³)
Aspiration	Naturally Aspirated
Governor and Protection	Woodward
Weight, Net Dry (approx)	970 kg (2138 lbs)
Capacity for Liquids	
Lube System (refill)	7 L (7.4 U.S. qts)
Cooling System	24.6 L (26.0 U.S. qts)
Oil Change Interval	500 hours
Rotation (from flywheel end)	Counterclockwise
Flywheel and Flywheel Housing	SAE No. 3

FEATURES

Improving Workforce Efficiency

- Standard factory certifications improve worksite safety
 - ATEX Directive (2014/34/EU) Group IIA
 - Category 3G (Zone 2) Temperature Class T3.
- Certified flameproof intake system to prevent any internal explosions from propagating to external atmosphere
- ATEX-designed and tested exhaust system, compliant to EN 1834-1

Making Your Investment Work Harder

- Maintains high power over broad range of operating speeds, improving performance
- Steady torque rise provides superior load acceptance
- Optimized ambient and altitude capabilities for operating flexibility

Committed to Sustainable Development

- Meets today's emission standards for well service applications
 - CCNR Stage 2/U.S.A. 40 CFR Part 94 Marine Tier 2

Driving Down Total Cost of Ownership

- Improved serviceability versus the competition
- Industry-leading component overhaul life

HAZPAK SOLUTION

- Matched exhaust and inlet systems
- Integrated control system
- Take the risk out of specification and procurement of individual parts
- All skin temperatures and exhaust gas < 200°C (T3)
- Certified to maintain T3 skin temperatures for up to 45°C ambient applications

Class-leading safety

- ATEX 2014/34/EU
- Machinery safety directive 2006/42/EC
- IECEX

Superior corrosion resistance

- Marine grade solder dipped core radiator

STANDARD PACKAGE EQUIPMENT

Air Inlet System

ATEX-designed and tested inlet system, compliant to EN 1834-1; stainless steel flame arrestor; integrated air shutdown valve, activates on overspeed and emergency stop; available in hydraulic, pneumatic, electric configurations; air cleaner, single element canister type with service indicator and rain cap

Cooling System

Closed cooling system with air blast radiator and charge air cooling, marine radiator with full solder-dipped core, radiator cooled packages sized for 45°C ambient air temp, gear-driven centrifugal jacket water pump, de-aeration expansion tank, exhaust gas heat exchanger, additional heat load from exhaust heat exchanger included in cooling circuit

Exhaust System

ATEX-designed and tested exhaust system, compliant to EN 1834-1; comprised of exhaust gas heat exchanger; stainless steel flame arrestor; stainless steel spark arrestor; water-cooled exhaust manifold

Flywheel and Flywheel Housing

Fuel System

Mechanical fuel injection, primary fuel filter/water separator with 1/4" BSPP connectors (LH), secondary fuel filter (LH), fuel priming pump manual, fuel shutoff valve

General

Package ambient capability is -20°C to 45°C; mechanical systems are designed for Gas Group IIA; electrical systems are designed for Gas Group IIC; all systems meet temperature class T3 (200°C limit); includes a declaration of conformity for the entire package scope; radiator package, engine, and exhaust system fitted to sub-frame; air filter, fuel/water separator, remote oil filter installed and mounted; earth bonding per standard EN 60079-14

Lube System

Locking oil filter (LH), locking dipstick (LH), flame trap breather

OPTIONAL EQUIPMENT

Air Compressor

Single cylinder, 225 CC with head unloader

Charging System

12V, 45A alternator with 75AH battery pack

24V 16A alternator with 75AH battery pack

24V 25A alternator with 75AH battery pack

Control System

Local panel at side of engine, includes: coolant temperature gauge, lube oil pressure gauge, exhaust gas temperature gauge, exhaust gas backpressure gauge, engine speed gauge, stop switch

Exhaust System

18 dBA spark arrestor/muffler, ATEX-approved

Shutdown System

Pneumatic, hydraulic, and electric solutions

Starting System

Pneumatic, electric, and hydraulic starters available

PERFORMANCE DATA

Naturally Aspirated — 2200 rpm

General Performance Data				
Percent Load	Engine Power		Engine Torque	
	bkW	bhp	N•m	lb-ft
100	55	73.8	239	176
90	55	73.8	250	184
80	54	72.4	258	190
70	52	69.7	261	193
60	51	68.4	261	200
50	49	65.7	271	203
40	47.5	63.7	275	209
30	44.5	59.7	283	209
20	42	56.3	283	211
10	39	53.3	286	211

DIMENSIONS

RIGHT SIDE VIEW

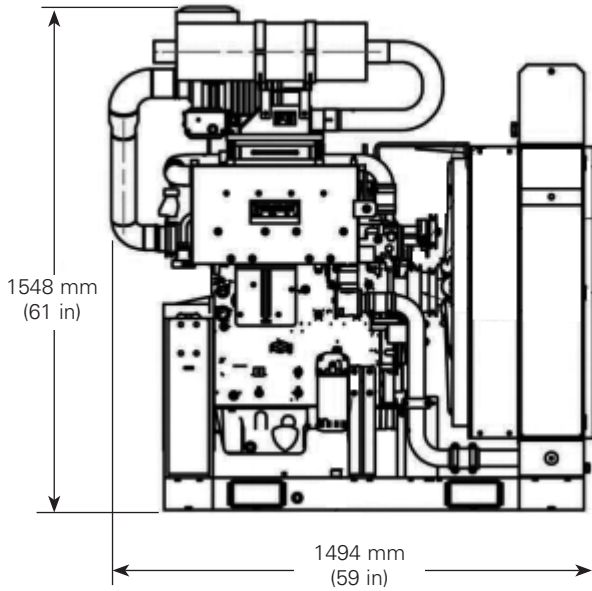

FRONT VIEW

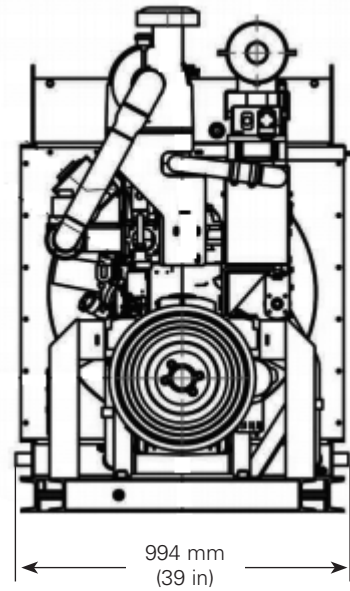

DIMENSIONS*		
Length	mm (in)	1494 (59)
Width	mm (in)	994 (39)
Height	mm (in)	1548 (61)
Shipping Weight	kg (lb)	970 (2138)

*Typical dimension shown. Height will increase if silenced spark arrestor is chosen.