

DESCRIPTION

The FPS76 starter motor is suitable for use on the CAT C7 engine (SAE #2 flywheel housing) in hazardous areas where explosive gasses occur (ATEX directive 99/92/EC).

The unit is supplied in a robust aluminum & mild steel flameproof casing. The unit includes 3m of supply cable wired through Exd glands (2 off M20's and 1 off M25) and an Exd blanking plug is used to blank out any unused (M20) entry points. The unit has double pole wiring which is insulated from chassis. An internal thermal switch prevents the motor and surface overheating and causing ignition.

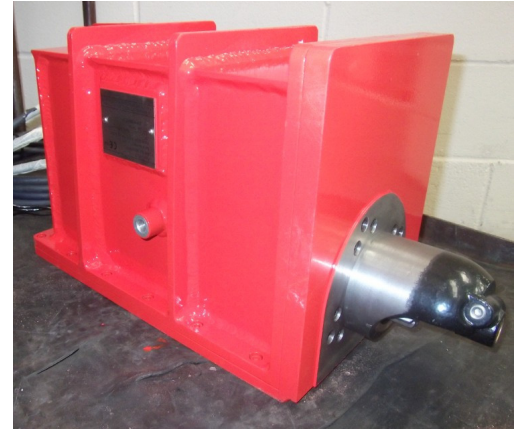

THIS EQUIPMENT MUST BE INSTALLED AND MAINTAINED IN ACCORDANCE WITH BS EN 60079-14 AND 17. FAILURE TO OBSERVE ANY INSTRUCTIONS IN THIS DATA SHEET MAY INVALIDATE ANY WARRANTY AGREEMENT.

TECHNICAL DATA

Label

Information:

PYROBAN	
Type: FPS76	CE 0518
Part No: 300825879	
Serial Number:.....	
Input: V:24 A:333 Rating: 8.0kW	
 II 3 G Tamb -20° to +45°C IIA T4 Gb	
13PYROBAN0255	
WARNING: DO NOT OPEN WHEN AN EXPLOSIVE ATMOSPHERE IS PRESENT	
<small>Pyroban Ltd, Shoreham-by-Sea, BN43 6QG, UK Telephone +44 (0) 1273 466200</small>	

Additional
Information:

Type of Protection	Flameproof
Standards of compliance	EN60079-0: 2012 EN60079-1: 2007
Ambient Temperature	-20°C to +45°C
Weight	48kg
Nominal Power	8.0kW
Part Numbers	300825879

INSTALLATION AND ELECTRICAL CONNECTIONS

Installation should be carried out in accordance with EN60079-14 or other national standards.

Under no circumstances should the weight of the unit be supported by its cables.

The unit may be fitted to a C7 engine (SAE #2 flywheel housing), with an appropriate pinion to suit the engine ring gear and an adaptor flange to fix it to the bell housing. The starter motor is not fitted near any hot spots on the engine deemed to affect its operation.

The unit is supplied with 2 off 35mm² power cables and a 4 core 6mm² cable which should be shortened to the required length (<3m): These must be terminated appropriately via suitable cable glands. The length of the power lead between the starter and the battery has a large effect on the starter output power and should be minimized. Power to the starter should be provided by a suitably protected battery.

The multi-core cable should have the green/yellow core connected to ground. The Trigger Cable (No. 1) needs to be suitably protected by a fuse (Fuse 1). The start current of the solenoid is 26A. Inside the starter motor are 3 temperature switches in series. These temperature switches have a recommended nominal current of 2A and are normally closed circuit. A suitable fuse (Fuse 2) should be chosen to protect the temperature switches. Ensure that the enclosure is electrically bonded to the chassis on which it is mounted.

Before attaching the motor to the flywheel housing the units cover needs to be removed. Access is required so that 3 off shoulder bolts are tightened to attach the motor to the engine. Pyroban does not make recommendations on starting mounting bolt torque, because the flywheel housing material and thread engagement length vary by application. No lock washers, star washers, soft washers, or copper electrical connections, should be used. When reattaching the aluminum lid to the mild steel plate the M6 fixings should not be torqued to more than 12 Nm to prevent the thread being damaged. A feeler gauge is recommended to ensure that the flamepath between the aluminum lid and mild steel adapter plate is maintained. The 0.15mm measure should be used. This measurement should not fit between the gaps. If the measure does, the fasteners located near the gap needs to be carefully torqued to eliminate the gap.

TYPICAL INSTALLATION – 4 CORE CABLE

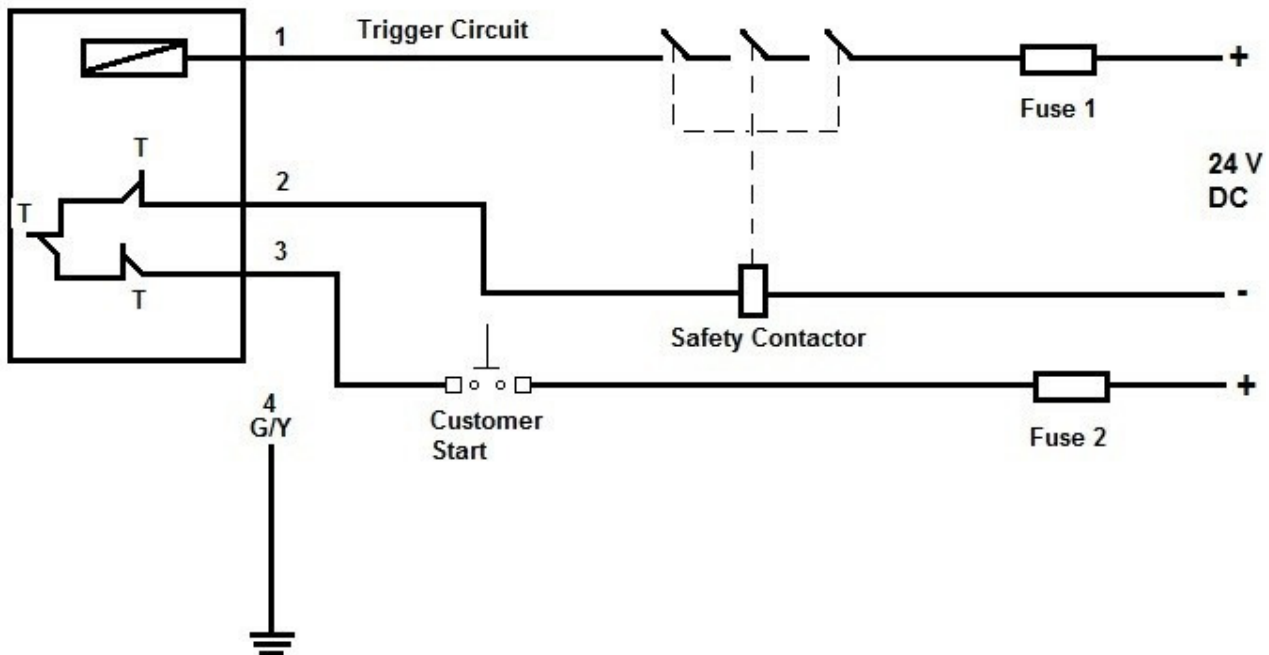

2 off 35mm² cables are supplied as part of the motor assembly. These cables are marked “+” for positive and “-” for negative and need to be connected to a positive and negative terminals of a suitable 24V battery supply. It is not recommended to switch the polarity of the starter motor.

INSPECTION AND MAINTENANCE

Maintenance may not take place in a hazardous area.

The starter contains no user serviceable parts.

6 monthly, check gland tightness and casing screw tightness.

Should the unit suffer impact or damage, the casing must be checked for permanent deformation. Should flameproof joints be damaged, the unit must be sent back to Pyroban for repair or replacement. Should the glands or blanking plug be damaged, they must be replaced with a suitable flameproof gland or blanking plug and the entry threads of the casing checked.

A record must be kept of all maintenance and repairs to EN60079-17

DIMENSIONS

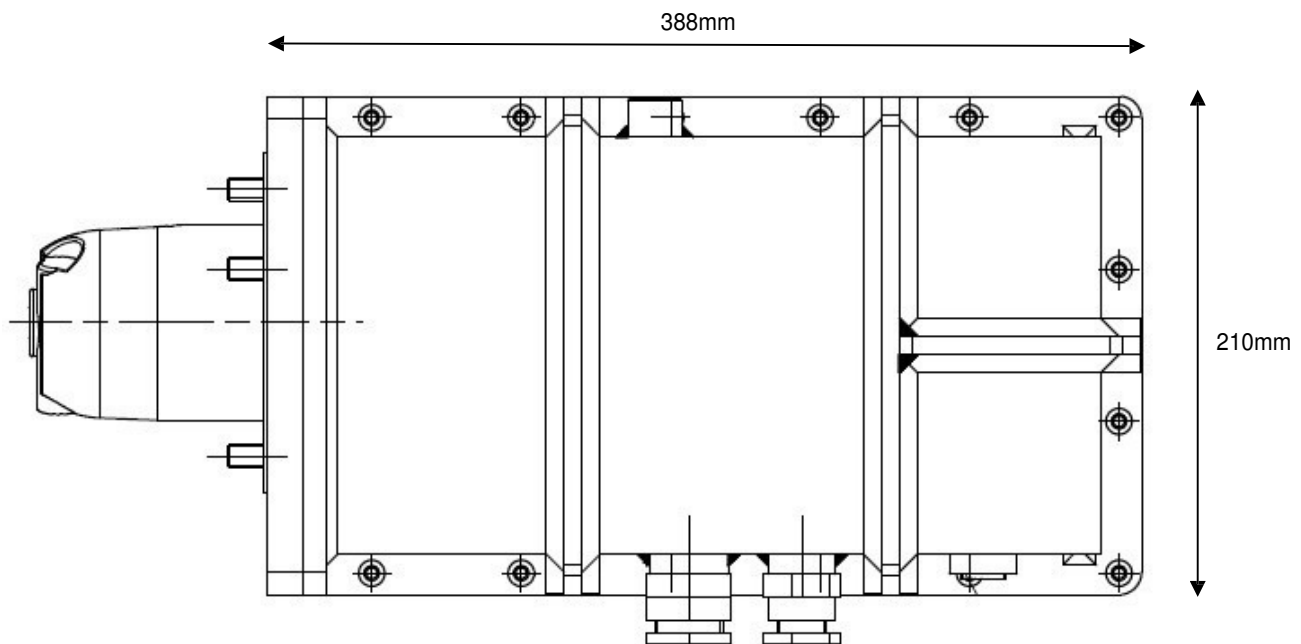

The unit measures 388mm in length, 260mm in width and 210mm in height.

DECLARATION OF CONFORMITY

We, Pyroban Limited, Dolphin Road, Shoreham-by Sea, Sussex, BN43 6QG, UK, declare that the component mentioned in this data sheet has been designed and manufactured in accordance with the essential health and safety requirements of Directive 94/9/EC(ATEX) inclusive of subsequent amendments. Compliance with these Directives is established by meeting the technical requirements of the relevant CEN and CENELEC standards.

Steve Noakes
Engineering Manager

OTHER INFORMATION

Nothing contained in this brochure is intended to extend any warranty or representation, expressed or implied, regarding the products described herein. Any such warranties or other terms and conditions of sale of products shall be in accordance with Pyroban's standard terms and conditions of sale for such products, which are available upon request. Specifications and machinery may be altered without notice at any time.

CONTACTS

Pyroban Limited Dolphin Road Shoreham-by-Sea W. Sussex BN43 6QG United Kingdom	Pyroban Benelux BV Grotenoord 24-26 - 3341 LT P.O. Box 229-3340 AE AEHendrik Ido Ambacht Nederland	Pyroban Suzhou Workshop B2, No. 2 Weixin Road, Suzhou Industrial Park 215122 Suzhou Jiang Su Province P.R.China
Telephone: +44 (0) 1273 456800 Email: customerservice@pyroban.com	Telephone: +31 (0) 78 6819377 Fax: +31 (0) 78 6818213 Email: sales@pyroban.nl	Telephone: +86(0) 512.62752808 Email: pyrobansuzhou@pyroban.com

www.pyroban.com